

## TOSVERT VF-nC1

VF-nC1 is a Compact, user friendly Inverter drive suitable for low power applications.

Main Power terminals use a screw clamp design, encapsulated within the compact body that enables simple installation. High torque at low speed with Toshiba's new motor control software makes it easy to apply to a wide range of applications. VF-nC1 also meets major Global Standards and accepts a wide input power supply range.

### Easy selections

- VF-nC1 meets major global standards: UL/CSA, CE and C-tick
- High carrier frequency capability reduces audible motor noise.
- VF-nC1 can detect analog input (4-20mA) failure.
- Built in cumulative operation timer for planned maintenance.
- Model with Built in Class B EMC noise filter available.

### Easy wiring and installation

- Main power terminal is located on the top and bottom enabling quick installation.
- Screw clamp design of the power terminals allows easy and secure connection.
- Side by side installation minimises installation space.
- Control circuit I/O logic (Sink/Source) is parameter selectable.
- Optional DIN rail mounting kit, up to 0.75kW, allows fixing free installation.

### Easy operation and commissioning

- RUN/STOP keys and potentiometer on front panel allows simple operation.
- New motor control software provides high starting torque at low speeds.
- Wizard function simplifies parameter setting.
- All models have PI control function for pump and fan applications.
- VF-nC1 has a serial communication port for network connection as standard.



### Global Standard



Input voltage class	0.1kW	0.2kW	0.4kW	0.75kW	1.5kW	2.2kW
<b>1-phase 230V</b> (European model)						

## Standard specifications

Item			Specification					
Input voltage			1-phase 100V/1-phase 200V/3-phase 200V					
Applicable motor (kW)			0.1	0.2	0.4	0.75	1.5	2.2
Model	Voltage Class	Type-Form	VFNC1/VFNC1S					
			---				---	---
Rating	1-phase 200V (European model)	VFNC1S-	---	2002PL	2004PL	2007PL	2015PL	2022PL
	Capacity(kVA) Note1)		0.3	0.6	1.0	1.6	2.9	3.9
	Rated output current(A) Note2)		---					
	Capacity(kVA) Note1)		---	0.5	0.9	1.5	2.9	4.0
Power supply	Rated output current(A)	1-phase 200V (European model)	---	1.1	2.1	3.6	6.8	9.6
	Voltage-frequency		200V class: 1-phase 200V-240V-50/60Hz					
Control function	Allowable fluctuation		Voltage +10%, -15%, frequency ±5%					
	Control system		Sinusoidal PWM control					
	Rated output voltage		Adjustable within a range of 100 to 125% of the corrected supply voltage(200V) (Unadjustable to any voltage higher than the input voltage).					
	Output frequency range		0.5 to 200Hz, default setting: 0.5 to 80Hz, maximum frequency: 30 to 200Hz.					
	Overload current rating		150%-60 seconds					
	Input terminal functions		Forward/reverse run, jog run, standby signal, preset-speed operation, reset, etc. / Switching between sink/source.					
Environments	Use environments		Indoor, altitude: 1000M(Max.), not exposed to direct sunlight, corrosive gas, explosive gas or vibration (less than 5.9m/s <sup>2</sup> ) (10 to 55Hz).					
	Ambient temperature / Relative humidity		-10-50°C (Above 40°C: Remove the protective seal from the top of VF-nCI) / 20 to 93% (free from condensation and vapor).					
Protective method / cooling method			---					
	1-phase 200V (European model)		---	Enclosed type IP20 / Self cooling			Enclosed type IP20 / Forced air-cooled	

Note1) Capacity is calculated at 220V, and at 240V for the European model.

Note2) In case of PWM carrier frequency : 4kHz or less.

## External dimensions/weights

Voltage class	Applicable motor capacity(kW)	Inverter type	Dimensions(mm)			Approx. weight (kg)
			Wide	Height Note1)	Depth	
1-phase 100V	0.1	VFNC1S-0100PL	72	130(142)	100.4	1.0
	0.2	VFNC1S-0200PL	72	130(142)	124.4	1.0
	0.4	VFNC1S-0400PL	72	130(142)	137.4	1.0
	0.75	VFNC1S-0750PL	117	130(142)	154.9	1.5
1-phase 200V (European model)	0.2	VFNC1S-2002PL	72	130(142)	100.4	1.0
	0.4	VFNC1S-2004PL	72	130(142)	124.4	1.0
	0.75	VFNC1S-2007PL	72	130(142)	137.4	1.0
	1.5	VFNC1S-2015PL	117	130(142)	154.9	1.5
	2.2	VFNC1S-2022PL	117	130(142)	154.9	1.5

Note1) Maximum size included mounting part.

## Standard connection diagram: Sink(common:CC)

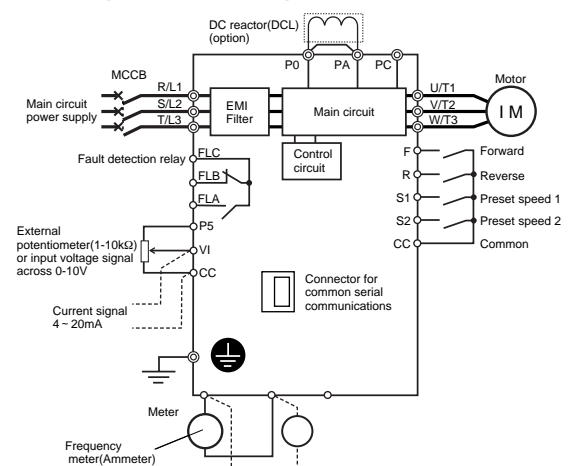

- 1 European model has an EMI Filter inside.
- 2 FMOUT and VI terminals are switched by the parameter.
- 3 VI terminal is switched for input terminal by the parameter.

**To users of our inverters :** Our inverters are designed to control the speeds of three-phase induction motors for general industry.

### Precautions

- \* Read the instruction manual before installing or operating the inverter unit and store it in a safe place for reference.
- \* When using our inverters for equipment such as nuclear power control equipment, aviation and space flight control equipment, traffic equipment, and safety equipment, and there is a risk that any failure or malfunction of the inverter could directly endanger human life or cause injury, please contact our headquarters, branch, or office printed on the front and back covers of this catalogue. Such applications must be studied carefully.
- \* When using our inverters for critical equipment, even though the inverters are manufactured under strict quality control always fit your equipment with safety devices to prevent serious accident or loss should the inverter fail (such as failure to issue an inverter trouble signal).
- \* Do not use our inverters for any load other than three-phase induction motors.
- \* None of Toshiba, its subsidiaries, affiliates or agents, shall be liable for any physical damages, including, without limitation, malfunction, anomaly, breakdown or any other problem that may occur to any apparatus in which the Toshiba inverter is incorporated or to any equipment that is used in combination with the Toshiba inverter. Nor shall Toshiba, its subsidiaries, affiliates or agents be liable for any compensatory damages resulting from such utilization, including compensation for special, indirect, incidental, consequential, punitive or exemplary damages, or for loss of profit, income or data, even if the user has been advised or apprised of the likelihood of the occurrence of such loss or damages.

**For further information, please contact your nearest Toshiba Representative or International Operations-Producer Goods. The information in this brochure is subject to change without notice.**

# TOSHIBA

**Hardmeier Control**  
 Weststrasse 115  
 CH - 8408 Winterthur  
 Tel. +41 (0)52 355 12 12  
 Fax +41 (0)52 355 12 11  
[www.hardmeier-control.ch](http://www.hardmeier-control.ch)